

# waterproofing planter boxes.

water  
damages  
exterior  
applied  
finishes and  
surrounding  
areas  
unless it is  
controlled.

**Drainage is needed and waterproofing is easy. It's an investment without risk.**

Unless drainage is provided a host of problems will occur :- footings, mortar, bricks and foliage are adverse effected by water damage. Correct waterproofing adds value to your investment. No damage. No risk.

Step 1

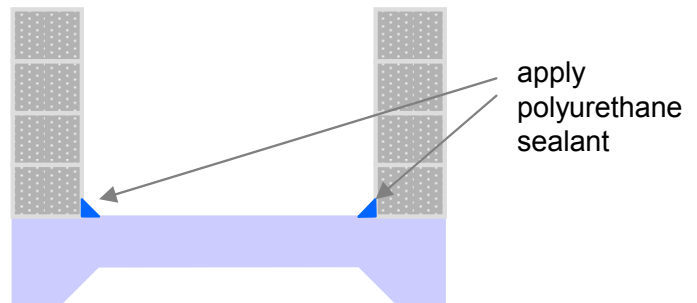

Step 2

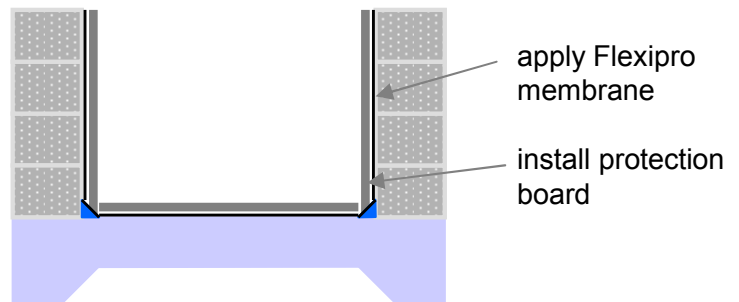

Step 3

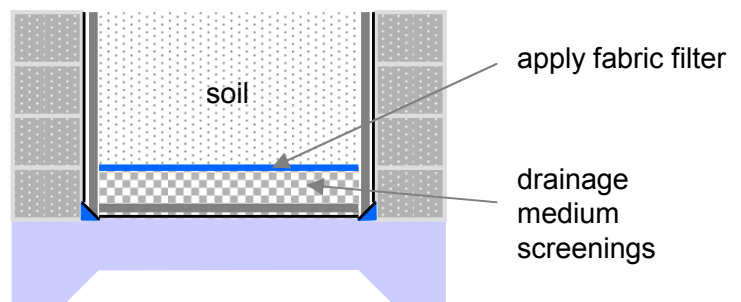

### Products:

Polyurethane Sealant  
Flexipro membrane  
Protection Board  
Fabric filter

technical information available on web page  
Meeting Australian Standards

